

MAGRON

FERROFLUID

MAGRON

Catalog No. 20240926

For Gas & Dust sealing

- Feedthrough 配件
- Vacuum Seal 配件

Contents

01	Ferrofluid for Gas&Dust Sealing Specification Corrosive(腐蚀性) gas, Non-Corrosive(非腐蚀性) gas, Grease Type	3p
02	TGA/DTA 测量 (热重分析 / 差示热分析)	5p
03	磁流体密封 什么是磁流体密封? / 优点 / Feedthrough配件图、分解图、运作原理	7p
04	使用磁性流体的Feedthrough与设备 半导体 / 显示器 / 资源&能源 / 制造业 / 核能&核聚变&军需	8p

Gas&Dust Sealing Specification

Non-use of PFAS

● For Corrosive gas

Carrier fluid: Perfluore Polyether [PFPE]

Item	Saturation Magnetization	Viscosity	Vapor Pressure		Torr· L/s Helium gas leak	1 wt% loss Temp. (TGA)	Pour point	Density
			Pa at 20°C	Torr mmHg. at 20°C				
Model	Gauss	mPa.sec (cP) at 27°C	Pa at 20°C	Torr mmHg. at 20°C	Less than 1E-11	°C	°C	g/cm ³
MFF-M4251	420	5,100	<5E-11	<3.75E-13	Ok	>280	<-40	2.198
MFF-M5286	520	8,600	<5E-11	<3.75E-13	Ok	>280	<-40	2.277
MFF-KD3847	380	4,700	<5E-11	<3.75E-13	Ok	>260	<-40	2.17
MFF-KD4350	430	5,000	<5E-11	<3.75E-13	Ok	>260	<-40	2.17
MFF-KR4549	450	4,900	<5E-11	<3.75E-13	Ok	>230	<-40	2.2
MFF-R6085	600	8,500	<5E-11	<3.75E-13	Ok	>140	<-40	2.25
MFF-R5050	500	5,000	<5E-11	<3.75E-13	Ok	>140	<-40	2.2
MFF-R4020	400	2,000	<5E-11	<3.75E-13	Ok	>140	<-40	2.14

*1 wt/% loss Temp. (TGA):加热时1%的重量蒸发或汽化而减重的温度。

(测量条件:用TGA测量仪每分钟升温10°C)

*实际温度会根据对磁性流体施加的温度、RPM、Shaft的直径、运作时间等条件而变化。

请根据上述条件决定使用温度。

*除上述规格外，也可按需定制。

*我们的磁性流体不使用PFAS (全氟和多氟烷基物质)

● 各型号的特点

MFF Series

耐化学性和耐辐射性卓越的系列。

MFF-M Series

对于活性气体来说，耐热性是世界上最好的型号。
真空排气时间短。(达到3.75E-13托的时间：3~5分钟)

MFF-M4251 Leak test data

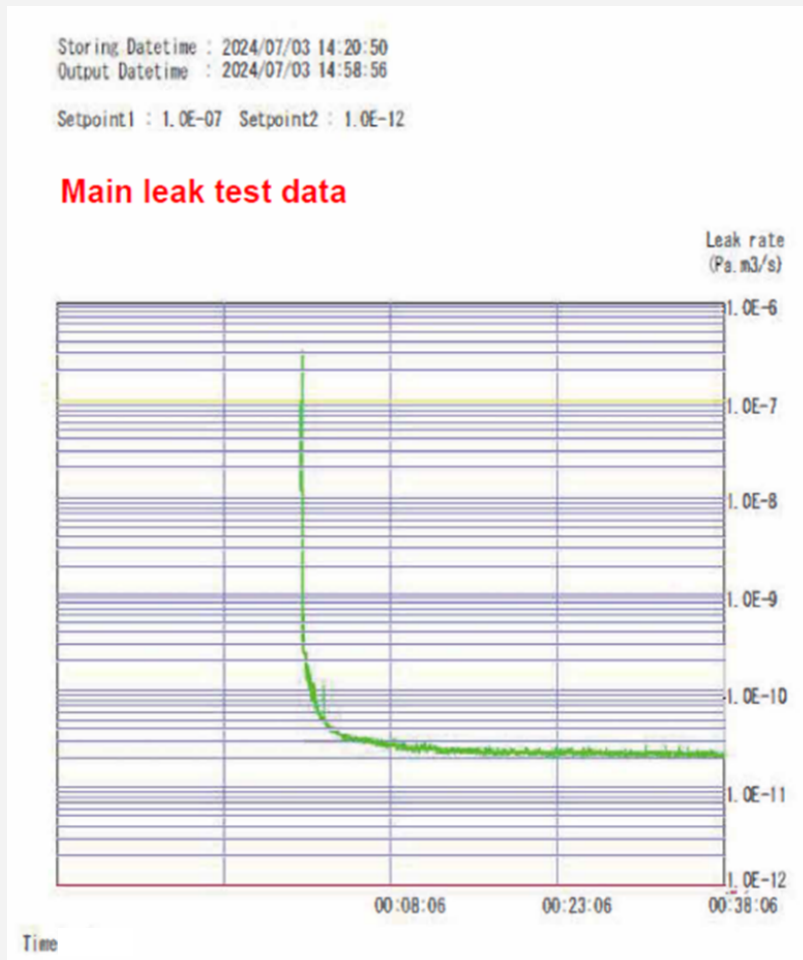

MFF-M5286 Leak test data

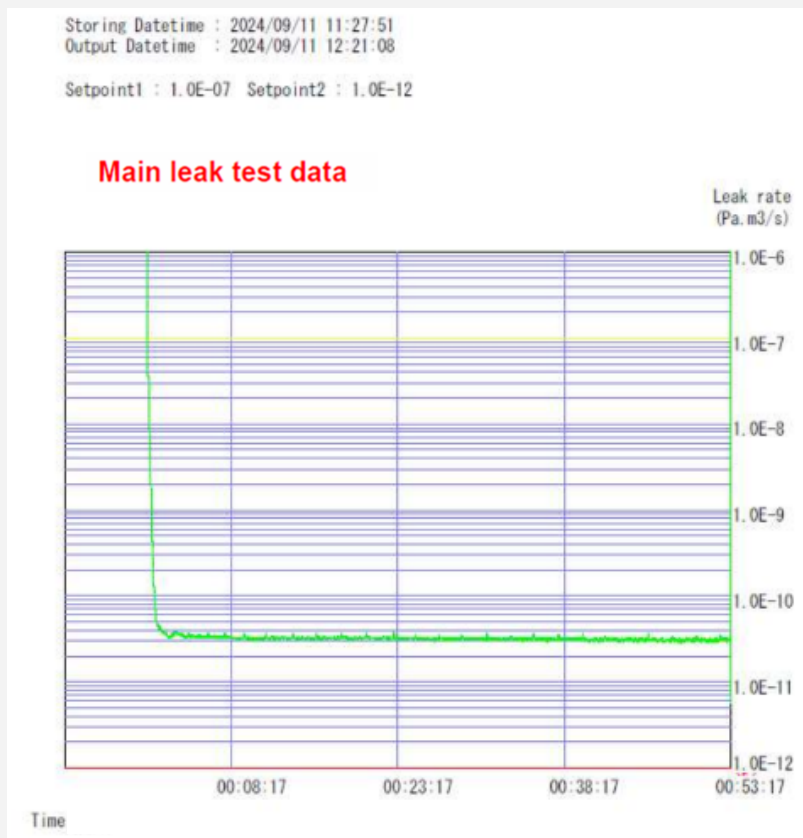

真空排放时间短且真空水平保持恒定。

Gas&Dust Sealing Specification

Non-use of PFAS

● For Non-Corrosive gas

Carrier fluid: MFS series - Silicon, MFH series Hydrocarbon

Item	Saturation Magnetization	Viscosity	Vapor Pressure		Torr- L/s Helium gas leak	1 wt/% loss Temp. (TGA)	Pour point	Density
			Pa at 20°C	Torr mmHg. at 20°C				
Model	Gauss	mPa.sec (cP) at 27°C	Pa at 20°C	Torr mmHg. at 20°C	Less than 1E-11	°C	°C	g/cm ³
MFS-7390	730	9,000	<5E-11	<3.75E-13	Ok	200	<-40	1.50
MFS-6022 (MFS-630)	600	2,200	<5E-11	<3.75E-13	Ok	200	<-40	1.39
MFS-5009 (MFS-513)	500	900	<5E-11	<3.75E-13	Ok	200	<-40	1.31
MFS-4005 (MFS-407)	400	500	<5E-11	<3.75E-13	Ok	200	<-40	1.21
MFH-7730	770	3,000	<5E-11	<3.75E-13	Ok	170	<-40	1.52
MFH-6206	620	650	<5E-11	<3.75E-13	Ok	170	<-40	1.39
MFH-5002 (MFH-503)	500	210	<5E-11	<3.75E-13	Ok	170	<-40	1.30
MFH-4401	440	150	<5E-11	<3.75E-13	Ok	170	<-40	1.22

*1 wt/% loss Temp. (TGA):加热时1%的重量蒸发或汽化而减重的温度。

(测量条件:用TGA测量仪每分钟升温10°C)

*实际温度会根据对磁性流体施加的温度、RPM、Shaft的直径、运作时间等条件而变化。

请根据上述条件决定使用温度。

*除上述规格外，也可按需定制。

*我们的磁性流体不使用PFAS (全氟和多氟烷基物质)

● 各型号的特点

MFS-Series

对于惰性气体，耐热性是世界上最好的系列。

MFS-4005

MFS Grade中最广泛使用。

MFH-5002

即使放置长时间后再启动，其起动转矩极少。

● Grease type

For Non-Corrosive gas&dust sealing + Lubrication

MFG-50	500		1E-10	7.5E-13	Ok	140	>400	-90	1.4
--------	-----	--	-------	---------	----	-----	------	-----	-----

*形状与Grease相似，并非液体。

TGA&DTA 测量

TGA

: Thermo Gravimetric Analysis (热重分析)

测量在不同温度下试料重量的变化，且与热分析同时进行。

即，可知在不同温度下的气化、蒸发、酸化量。

能够推测可在高温使用的温度。

DTA

: Differential Thermal Analysis (差示热分析)

可得知是否与吸热、发热发生了化学反应。

可得知引起相变、还原、分解、酸化的温度。

MFF-M Series

(每分钟上升温度：10摄氏度)

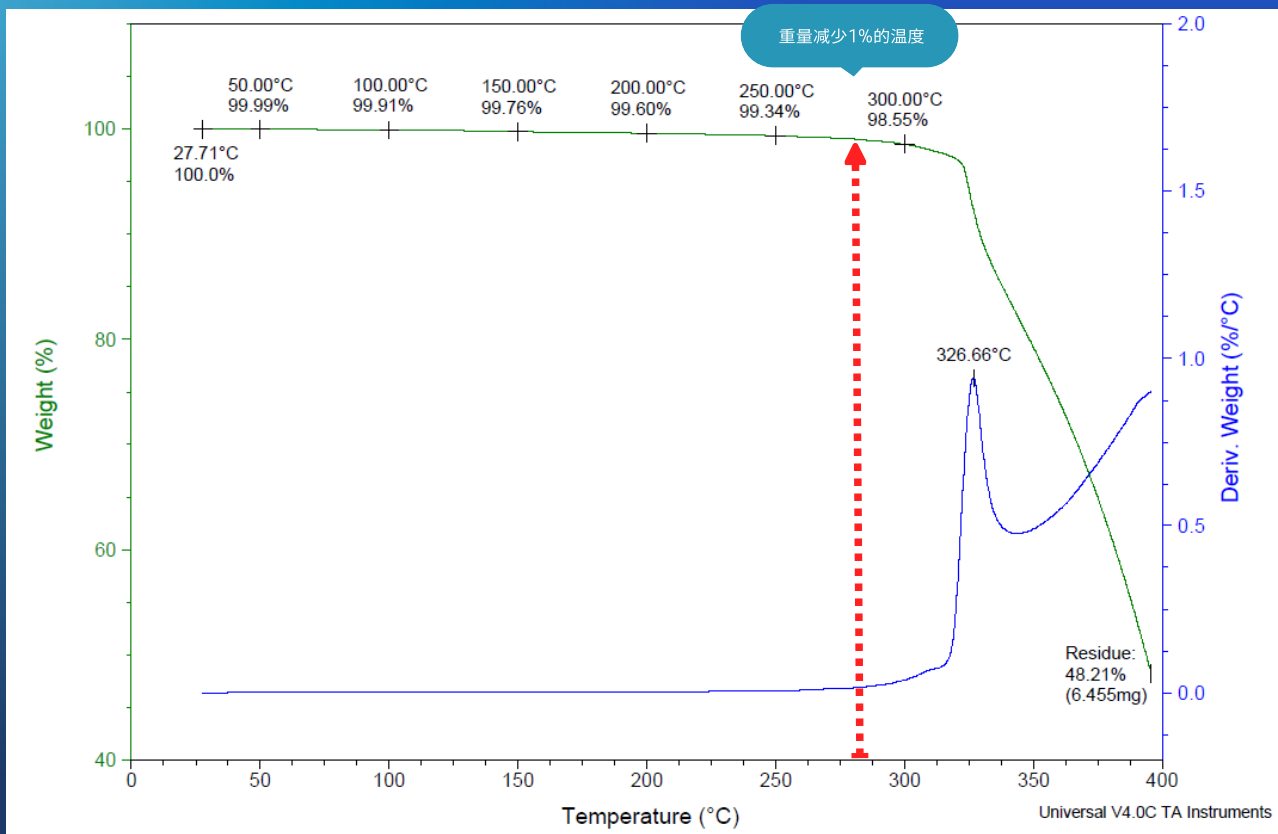

MFF-KD Series

(每分钟上升温度 : 10摄氏度)

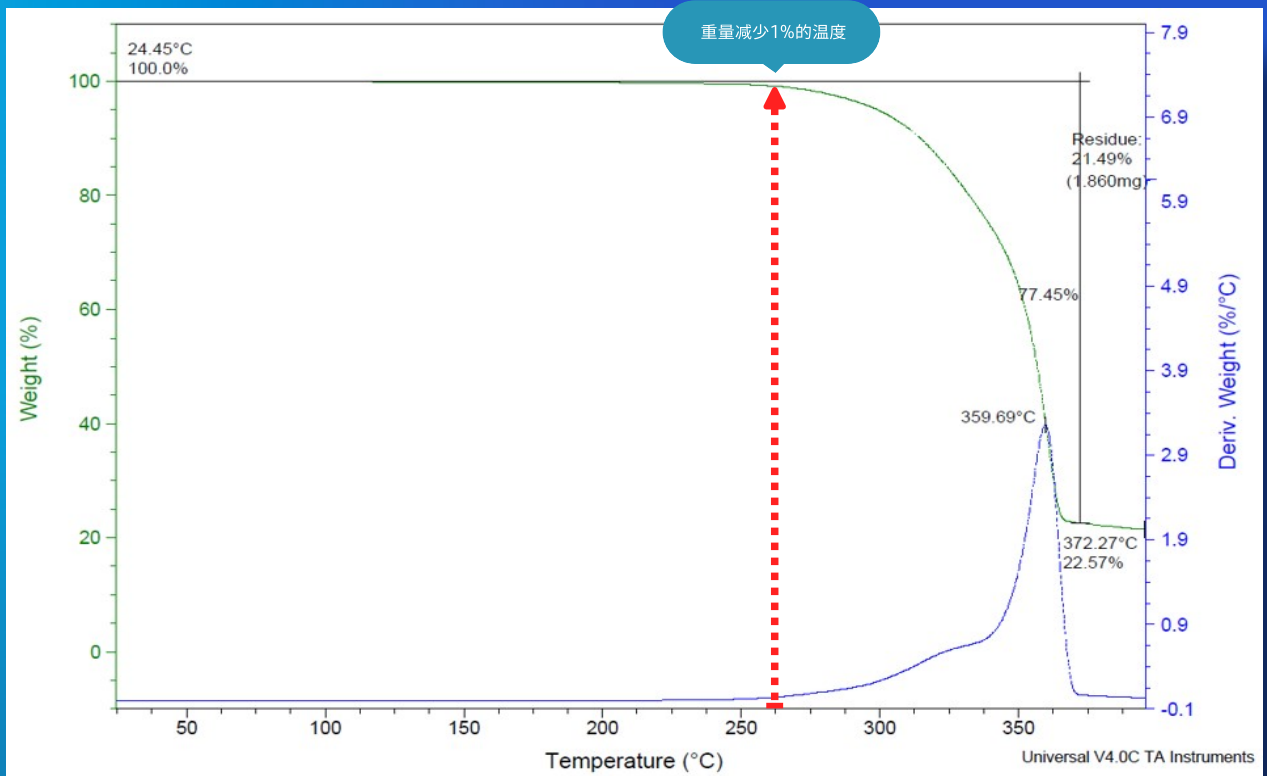

MFF-KR Series

(每分钟上升温度 : 10摄氏度)

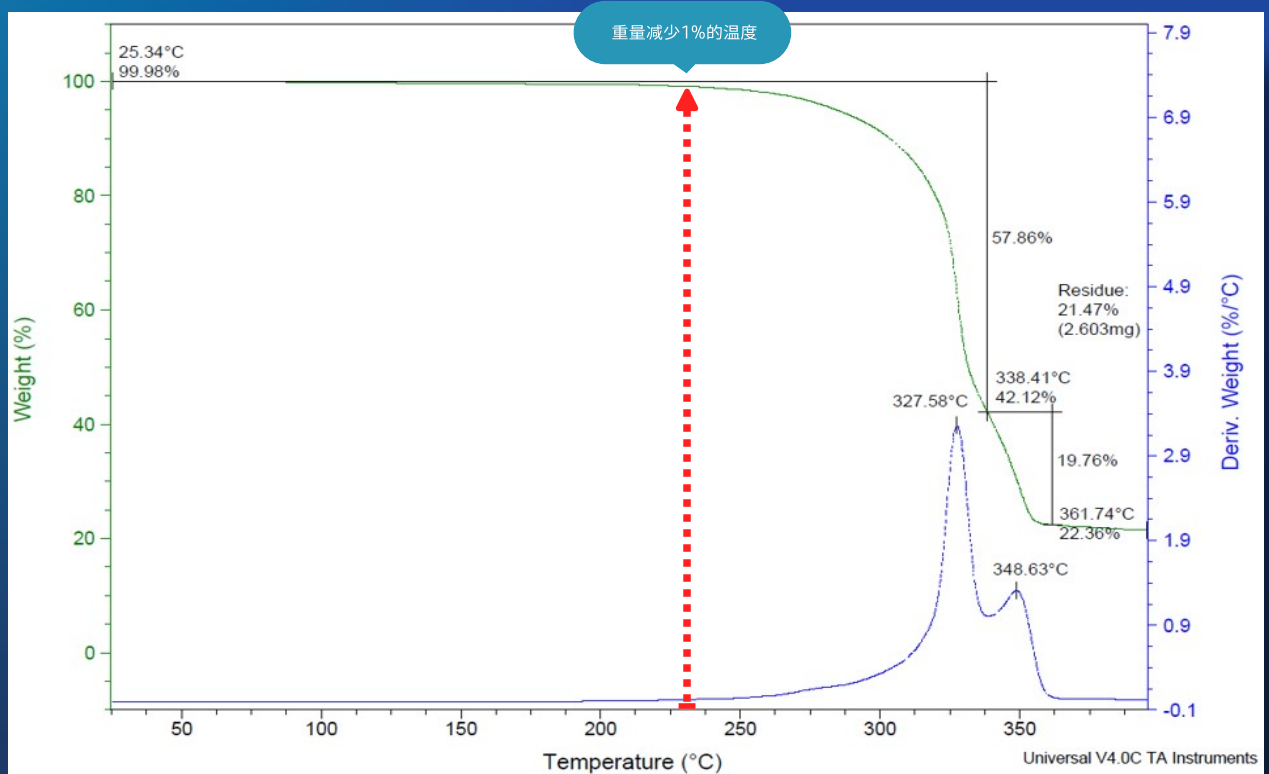

MFS Series

(每分钟上升温度 : 10摄氏度)

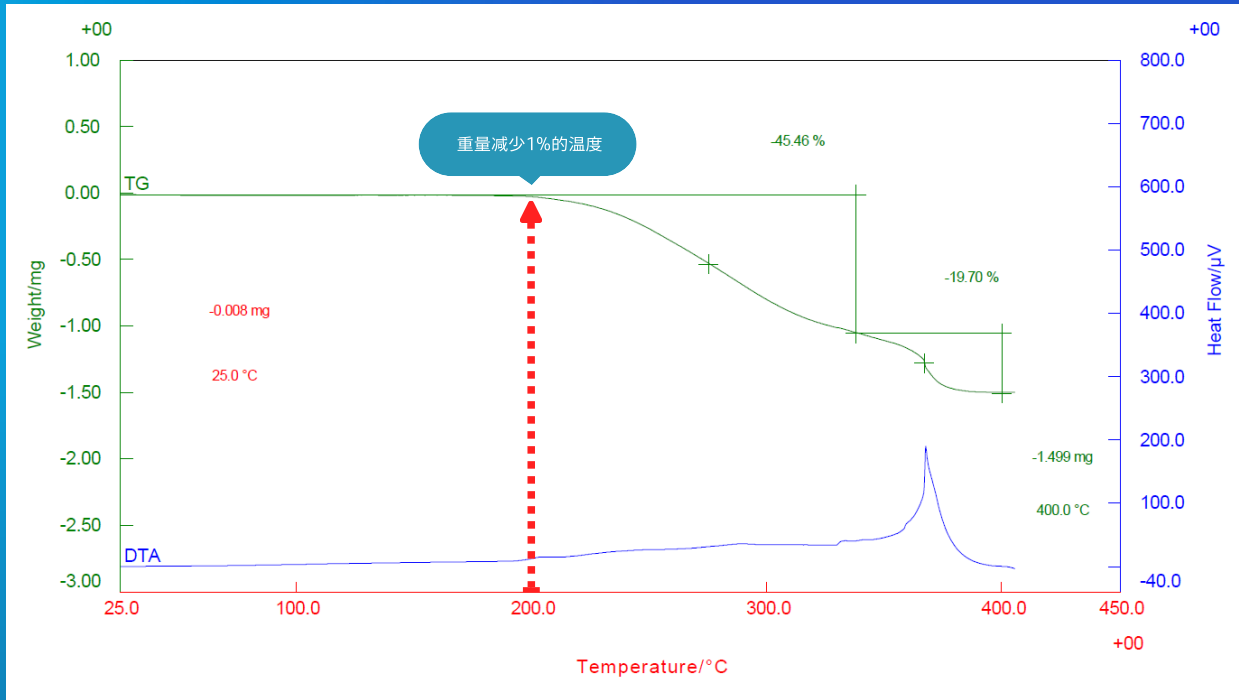

MFH Series

(每分钟上升温度 : 10摄氏度)

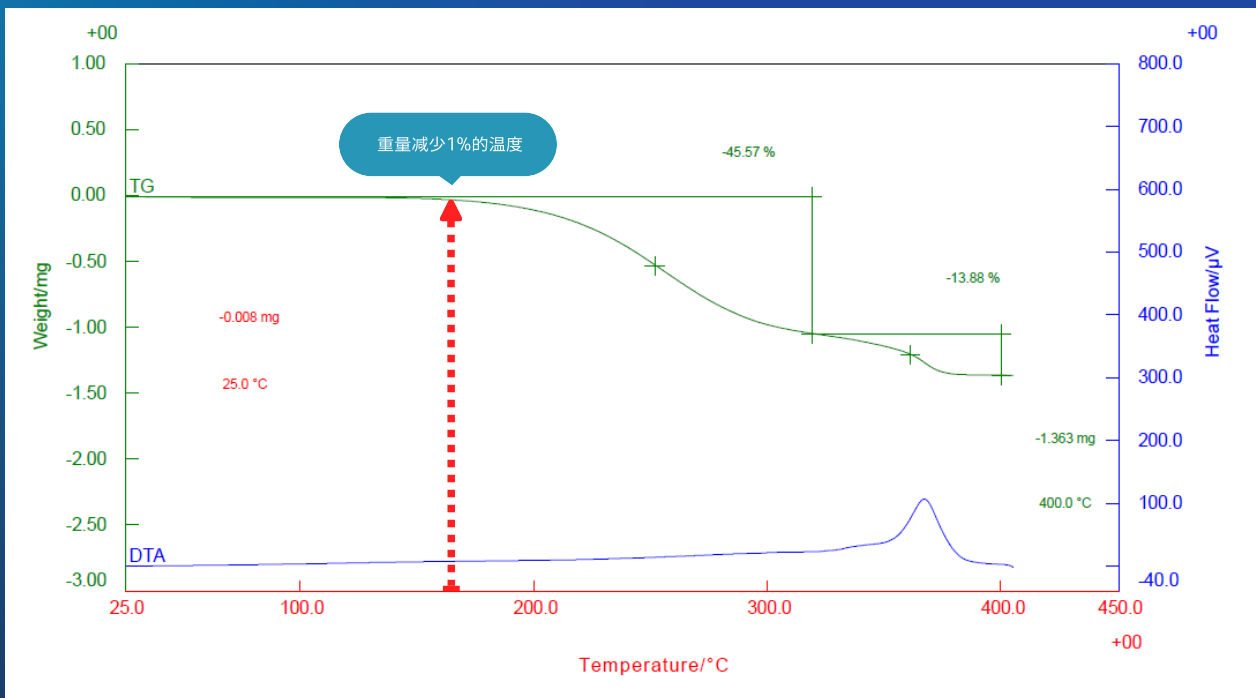

Ferrofluid Seal

什么是磁流体密封？

Ferrofluid Seal:

在磁铁与旋转轴之间，会通过磁铁与Pole piece形成磁场。在此间隙中注入磁性流体，便形成液体的O-圈型，即是起到Sealing作用的非接触Seal。Feedthrough使用多个磁性流体。每一圈型都可通过其压力容量，使其在真空状态下也能够保持原型，且总压力容量与各圈的压力容量的总合几乎一致。因没有摩擦，使设备更加耐用。且在超高真空状态下，可隔断有害气体及粉尘。

优点



Feedthrough 分解图

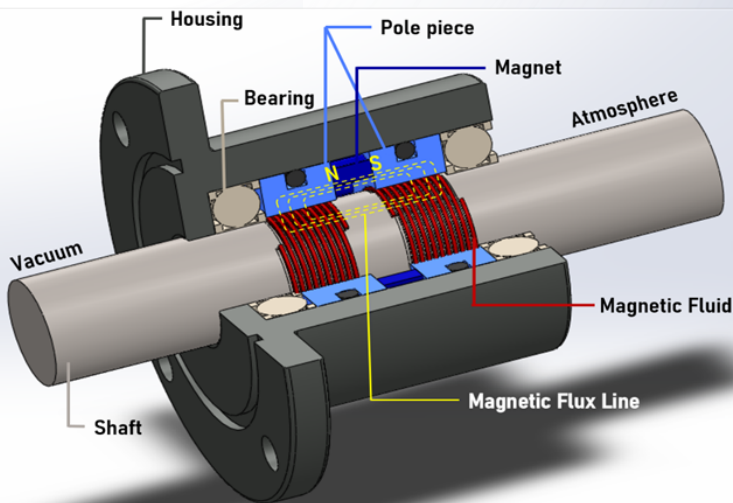

● ferrofluid

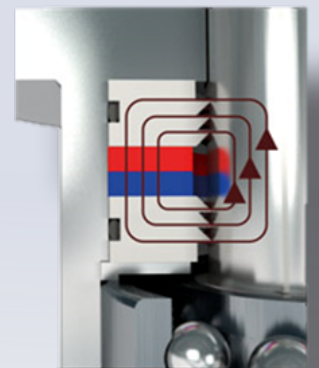
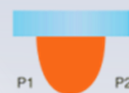

使用磁性流体的设备与领域

磁性流体与Feedthrough的适用



半导体



显示器



太阳电池、
电磁力、
核聚变



制造业



航空航天&
军需



- CVD
- Sputtering equipment
- Ion implanter
- Etching equipment
- Vacuum transfer robot
- Arc discharge
- Ion beam equipment
- Film panel
- LED, OLED manufacturing equipment
- Anode x-ray generator
- Vacuum chuck
- Solar panel
- New energy battery
- Single crystal growth
- Vacuum furnace
- Stirring assembly

Feedthrough



CVD



Ion implanter



Single crystal growth

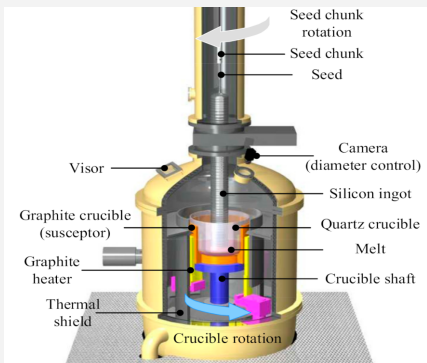

Sputtering equipment

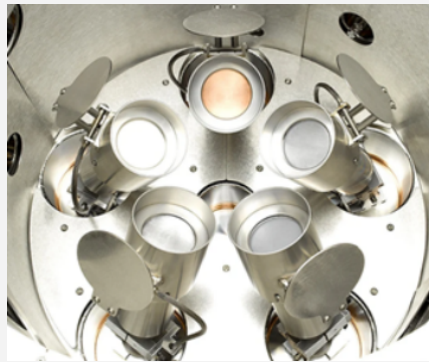

Etching equipment



Vacuum transfer robot



Vacuum chuck

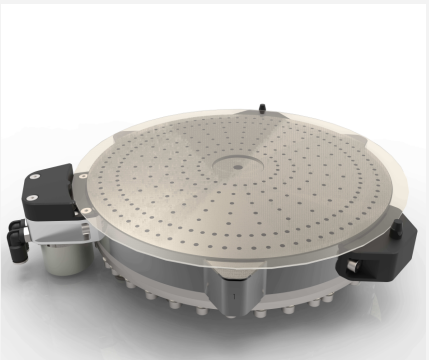

Ion beam equipment

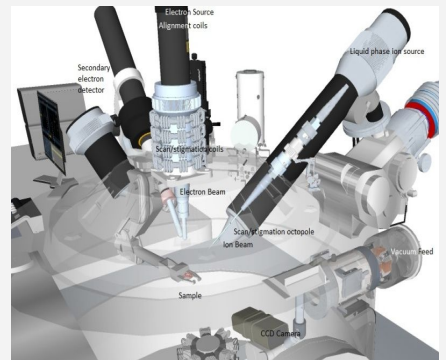

LED, OLED Film panel

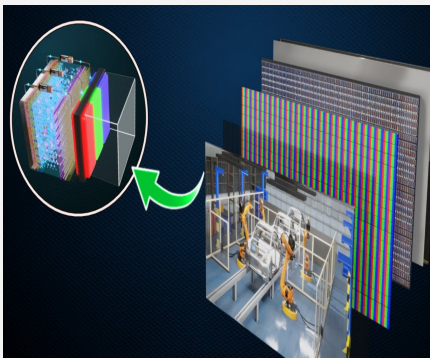

Anode x-ray generator

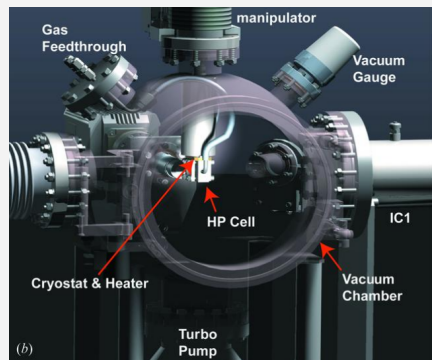

Solar panel



New energy battery



Nuclear power

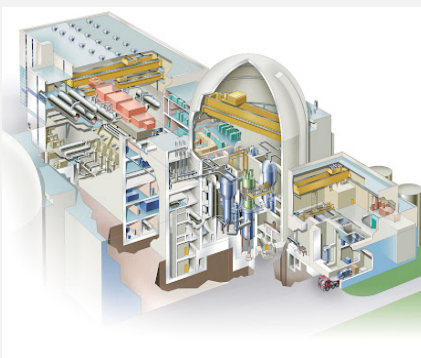

Nuclear fusion

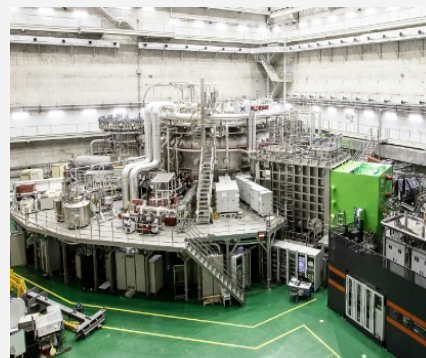

Medical equipment



Aerospace



Military



可按照贵公司所需量身定制。

我司正不断地开发并推出新的产品。

请联系我们。



Company information

Address	韩国京畿道安山市常绿区海岸路705京畿科技园3栋 403号 (邮件号码15588)	
Contact	电话：82-31-500-4633 (国内), 82-30-500-4632 (国外) 传真：82-31-500-4631	
电子邮件	magron@magron.co.kr	
网址	(KO) www.ferrofluidmagron.co.kr	(EN) www.ferrofluidmagron.com